

PFISTERER



Connectors, Clamps, Compensating Devices, Insulators
and Safety Equipment for Electrification of Rail

PFISTERER RAIL SYSTEMS

**Components and Systems for the
Electrification of Railway Lines.**



THORNE &
DERRICK
INTERNATIONAL

Thorne & Derrick
+44 (0) 191 490 1547
www.thorneandderrick.com

THE POWER CONNECTION



**THORNE &
DERRICK
INTERNATIONAL**

Thorne & Derrick
+44 (0) 191 490 1547
www.thorneandderrick.com



Welcome to the PFISTERER RAIL SYSTEMS Centre of Competence.

PFISTERER provides perfect solutions for railway systems. The technology developed in-house for the production of safe and reliable railway electrification material offers a comprehensive program of clamps and compensating devices. This also includes all necessary auxiliary equipment and tools.

We have extended this line to include a broad range of silicon and section insulators, as well as catenary geometry measuring devices.

All these products are complemented by a full range of voltage detectors and grounding equipment.

PFISTERER RAIL SYSTEMS offer you connectors and systems for the electrification of railway lines:

- **Hangers and Connectors**
- **Insulators and Suspensions**
- **Tools**
- **TENSOREX® System**
- **Safety Equipment**



THORNE &
DERRICK
INTERNATIONAL

Thorne & Derrick
+44 (0) 191 490 1547
www.thorneandderrick.com



Excellent Products for Excellent Means of Transport.

PFISTERER has been supplying products for railway electrification for more than 30 years which has shaped our product program. Our products have been installed worldwide in subway, tramway and high-speed lines becoming a reference for Railway Administrations.

The length of the subway, tramway and high-speed rail networks will more than double worldwide in the next 10 years due to an expanding market and changes in consumer demands. PFISTERER will be present in this growth supplying not only products but knowledge as well.

Our products are adapted to customer needs providing application and design support.

For example our patented **TENSOREX®** system has demonstrated a definite improvement in catenary

systems, introducing an innovative solution for the mechanical compensation of catenary cables, increasing efficiency and substantially reducing maintenance.

Our **hangers and connectors** have been successfully installed by major Railway Administrations both in local tramway, and in high-speed lines satisfying demanding requirements and achieving a high grade of performance.

Nowadays, **silicon insulators** are becoming more and more accepted due to their advantages: customized fittings, light weight, simple installation.

And in **safety equipment**, we have increased our range including variants to cover all the different operating voltages of the Railway Administrations.



THORNE &
DERRICK
INTERNATIONAL

Thorne & Derrick
+44 (0) 191 490 1547
www.thorneandderrick.com

Catenary fittings	Page 6 – 16	I
Cable and Track Connections	Page 17 – 25	II
Safety Equipment	Page 26 – 32	III
Monitoring Equipment	Page 33	IV



Solutions for railway electrification

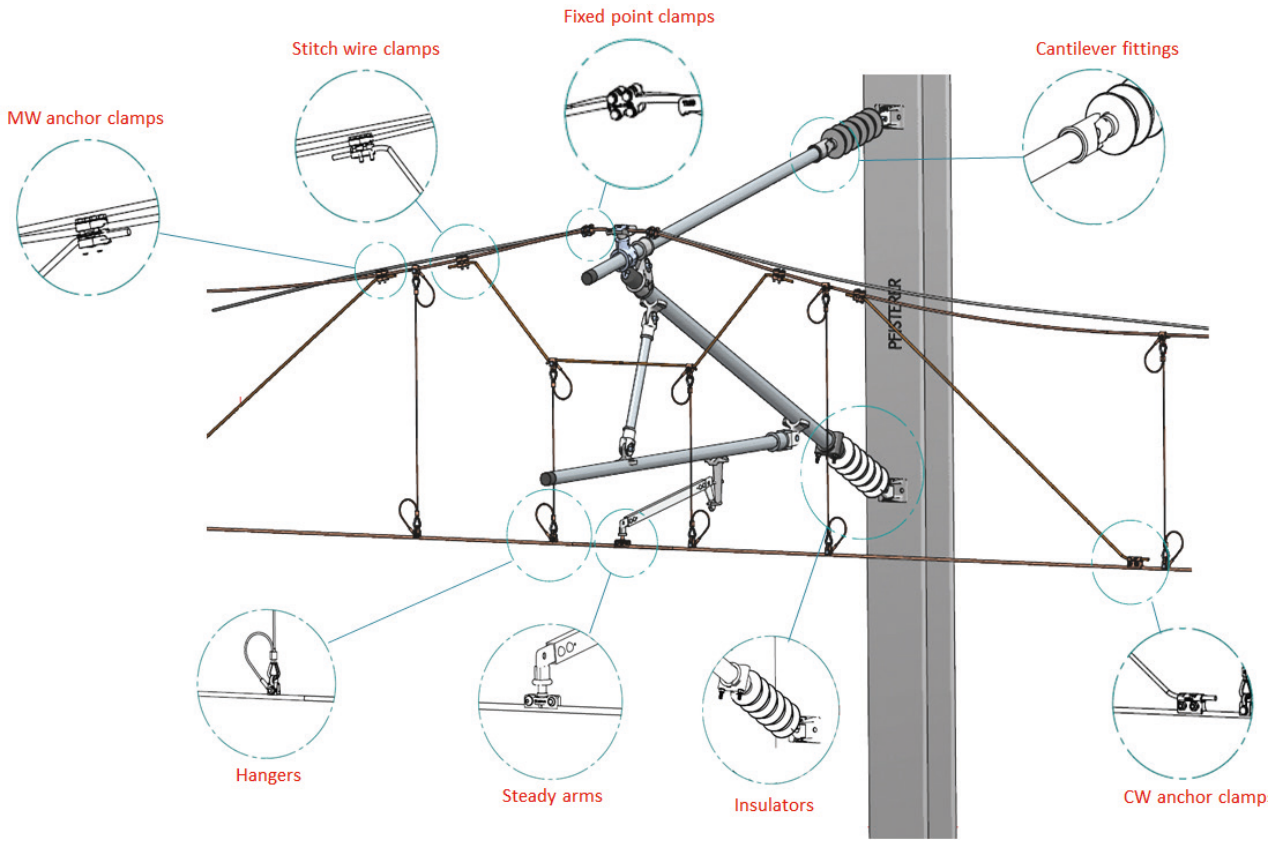

THORNE &
DERRICK
INTERNATIONAL

Thorne & Derrick
+44 (0) 191 490 1547
www.thorneandderrick.com

Current Carrying Dropper

Droppers are used for the full current carrying suspension / connection from / to the contact wire on the messenger wire

No.	Description	Material
PE.HC 107/CU70.10	Current Carrying Dropper	
305.859.002.70	Dropper clamp for CW and 65.81 mm ² MW	CuNi2Si
625.012.P10	Thimble	Nylon
TAI M10x30	M10 Screw	A2
ADI M10	Washer	A2
625.012.41	Splice	Copper
305.312.002	Splice	Copper

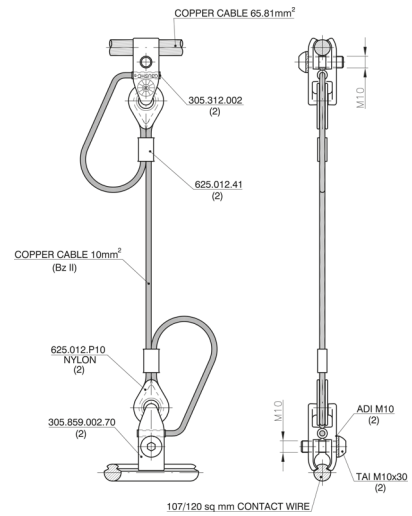

Application pictures:



Conductive Dropper



Steady arm clamps

This clamp is used to mount the contact wire with the steady arm with bolts.
Option: hexagonal bolts.

Material:
CuNi2Si
A2 screws

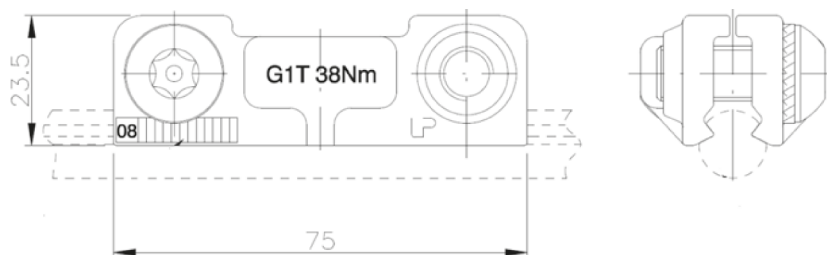
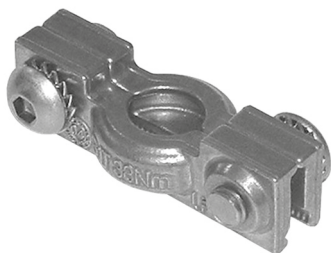

No.	No.	Contact wire cross section	Pivot outside diameter (mm)	Pivot inside diameter (mm)	Tightening Torque (Nm)	Weight (kg)	References
304 741 001	G-1T	Ri80 - Ri150	24.5	16	38	0.198	UK: NETWORK RAIL ADIF: 74.024.400 SBB, CHINA
304 742 001	G-1TA	Ri80 - Ri150	16	10.5	20	0.175	AVE

Application pictures:

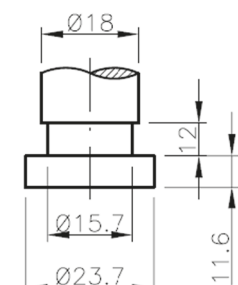

Pivot for G-1T

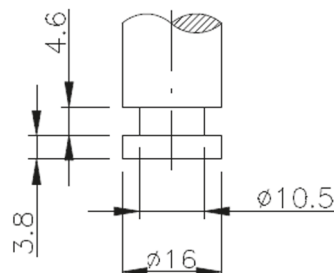

Pivot for G-1TA



G-1T on high speed



**THORNE &
DERRICK**
INTERNATIONAL

Thorne & Derrick
+44 (0) 191 490 1547
www.thorneandderrick.com

Contact wire Z-cable anchor clamps

This clamp is used to anchor the contact wire to the Z-cable.

Material:
CuNi2Si
Screws in A2

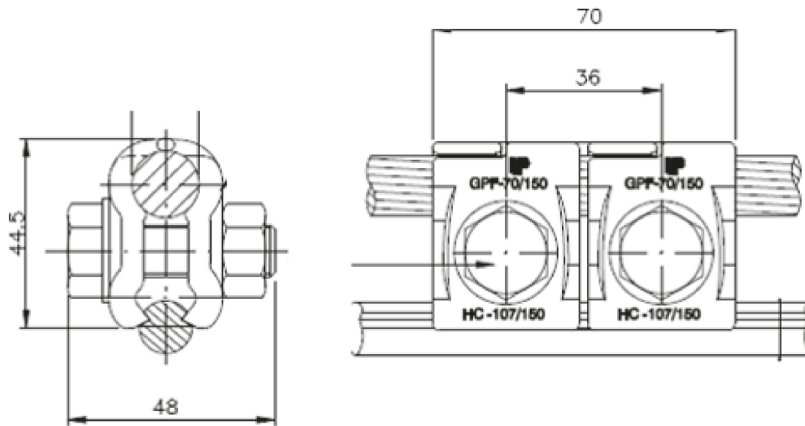
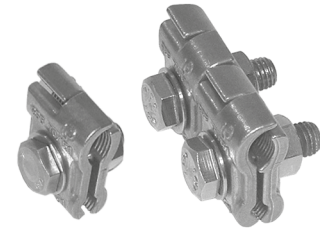

No.	No.	Contact wire cross section	Anchoring cable cross section (mm ²)	Number of screws	Tightening Torque (Nm)	Weight (kg)	References
325 102 001	GPF 70/150	Ri 80 - 150	70 - 150	2	65	0.44	UK: NETWORK RAIL AVE
-	GPF 70/150M	Ri 80 - 150	70 - 150	1	65	0.22	-

Application pictures:

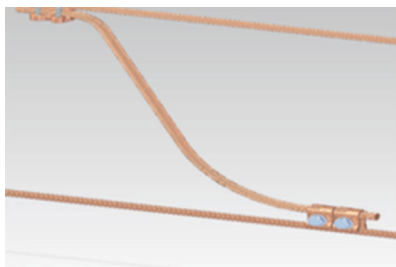

Z-cable anchorage



THORNE & DERRICK INTERNATIONAL

Thorne & Derrick
+44 (0) 191 490 1547
www.thorneandderrick.com



High Mechanical Working Load Clamps

This clamp, also known as an „elephant clamp“, is used for high mechanical load applications providing a full current connection as:

- Messenger wire anchor cable (Z-cable)
- Fixed point
- Stitch wire

Material:
CuNi2Si
Screws in A2

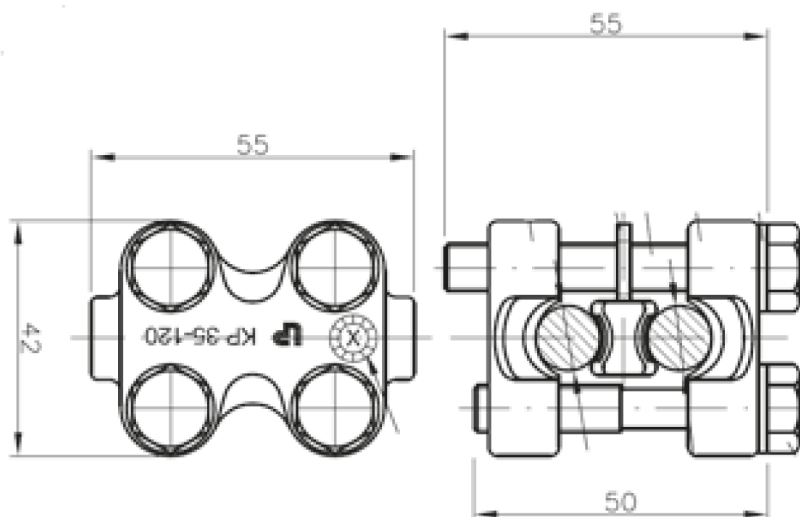

No.	No.	Cable cross section 1 (mm ²)	Cable cross section 2 (mm ²)	Main cable cross section (mm ²)	Derived cable cross section (mm ²)	Tightening Torque (Nm)	Weight (kg)	References
332 321 003	KP 25/70	25 - 70	25 - 70	25 / 70	25 / 70	20	0.362	DB: Ebs 07.42.42 Bl.1
332 321 005	KP 35/120	35 - 120	35 - 120	25 / 95	50 / 95	20	0.362	NETWORK RAIL AVE
-	KP 35/120#	-	-	70 / 120	70 / 120	20	0.362	AVE

Application pictures:



Fixed point clamp

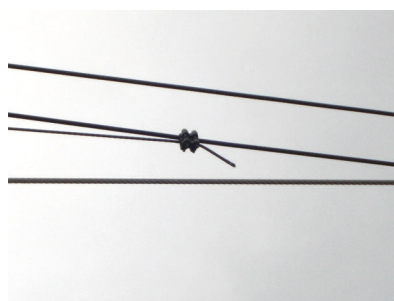

Stitch wire clamp

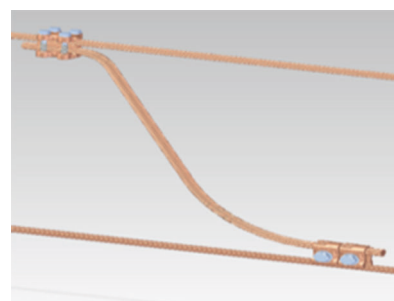

Messenger wire anchor clamp



THORNE & DERRICK
INTERNATIONAL

Thorne & Derrick
+44 (0) 191 490 1547
www.thorneandderrick.com

Railway Silicone Composite Insulators

Composite silicone insulators for 25 kV lines with the following advantages:

- Light weight
- Anti-vandalism
- Self cleaned with rain
- Suitable for polluted areas
- Easy to store and handle
- Manufactured according to IEC standards

Material:

Steel end fittings
Silicone insulators with fiberglass rod core

No.	Power frequency withstand voltage (wet) 1 min (kV)	Lightning impulse withstand voltage	Arcing distance (mm)	Minimum creepage distance (mm)	Specified mechanical load (SML) (kN)	Number of sheds	Approx. weight (kg)
144 034 001	115	250	461	1238	160	5/6	2.92
144 034 051	95	250	461	1238	135	10	3.1

Application pictures:



PFISTERER Insulators with TENSOREX

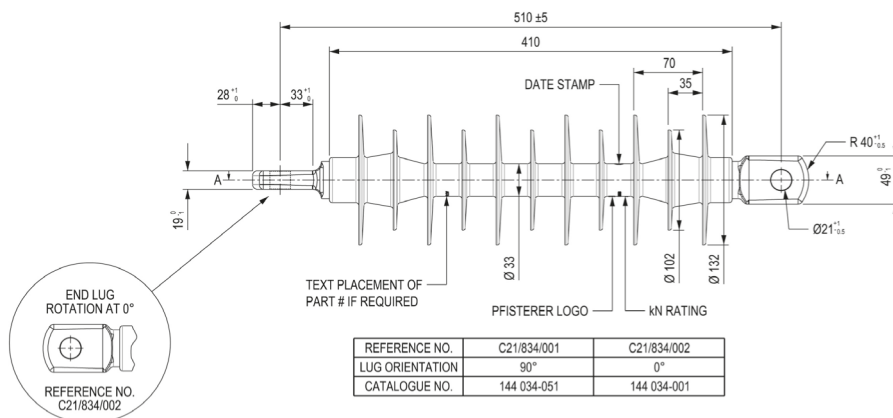

THORNE & DERRICK INTERNATIONAL

Thorne & Derrick
+44 (0) 191 490 1547
www.thorneandderrick.com



Contact wire splice, riveted

The riveted overhead traction wire splice is used to connect grooved overhead traction wire with full tension. It is fitted hydraulically with size III compression units.

Material:

High strength copper alloy clamping jaws CuNiSi
Copper rivet
Bare surface

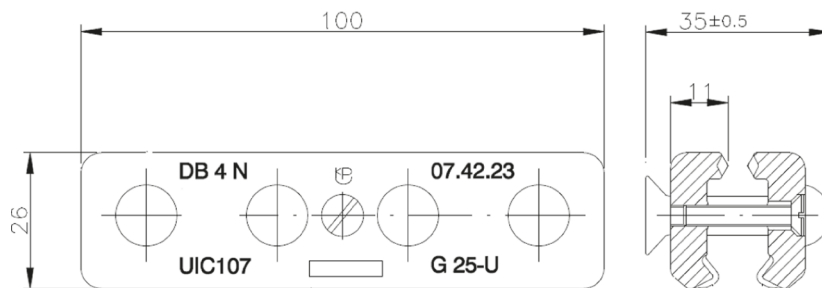

No.	No.	Contact wire cross section	Appropriate insert for compressing	Appropriate insert for removing	Number of rivets	Weight (kg)	References
302 391 391	-	Ri65 / 80 / 100 / 120	302 346 346 (DB 4 N)	302 345 345 (DB 4 L)	4	0.37	DB 07.42.23
-	302 910 910	65 / 120	-	-	6	-	-

Application pictures:



Contact wire splice



THORNE & DERRICK
INTERNATIONAL

Thorne & Derrick
+44 (0) 191 490 1547
www.thorneandderrick.com

Contact wire splice, screw-in

The screwed on overhead traction wire splicee is used to connect grooved overhead traction wires with full tension.

Material:

High strength copper alloy CuNiSi clamping jaws
A2 screws
Bare surface

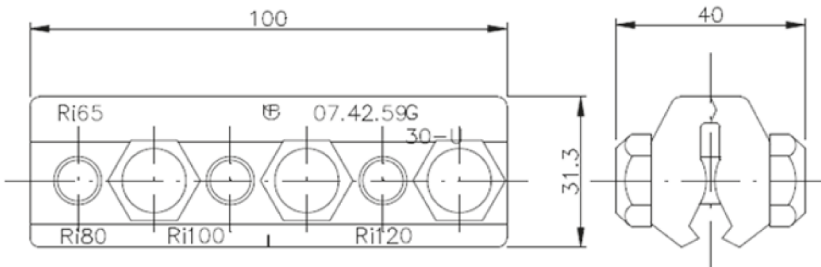

No.	No.	Contact wire cross section	Tightening Torque (Nm)	Weight (kg)	References
302 537 537	-	Ri80 - Ri120	20	0.5	UK Rail: 121/202/002
-	302 537 537 IT	80 / 120	20	0.9	RFI 774/215

Application pictures:



Contact wire splice



THORNE & DERRICK INTERNATIONAL

Thorne & Derrick
+44 (0) 191 490 1547
www.thorneandderrick.com



Earth stanchion clamp

The earth stanchion clamp has been developed to tension conductor wires on overhead catenary systems.

Material:
High strength aluminium alloy

No.	Wire Diameter (mm)	Working Load (kN)
244 340 320	9.0 - 24.5	300



Wedge clamp

The wedge clamps have been developed to tension conductor wires on overhead catenary systems.

Material:
High strength aluminium alloy

No.	BR References	Wire Diameter (mm)	Working Load (kN)	Conductor Wire	PADS No.
406 594 594	A	9.0 - 10.7	90	Copper or Steel	091/002341
406 594 595	B	10.8 - 12.5	90	Copper or Steel	091/002344
406 594 597	C	14.4 - 16.1	90	Copper or Steel	091/002345
406 598 602	D	16.2 - 18.2	90	Aluminium	091/002346
406 598 604	E	20.5 - 22.5	90	Aluminium	091/002347
406 594 003	F	18.3 - 20.4	160	Copper or Steel	091/002348
406 598 598	AS	9.0 - 10.7	90	Aluminium	091/002343
406 598 599	AL	10.8 - 12.5	90	Copper or Steel	091/002342



Wedge clamp body

No.	for Wire Diameter up to (mm)
438 158 001	9.0 - 24.5
438 158 002	24.5 - 32



Bolt Electrical Connection Clamps

This clamp is used to provide a full current connection between:

- Messenger wire and feeding cable
- Contact wire and feeding cable

Material:
 Brass
 Screws in A2

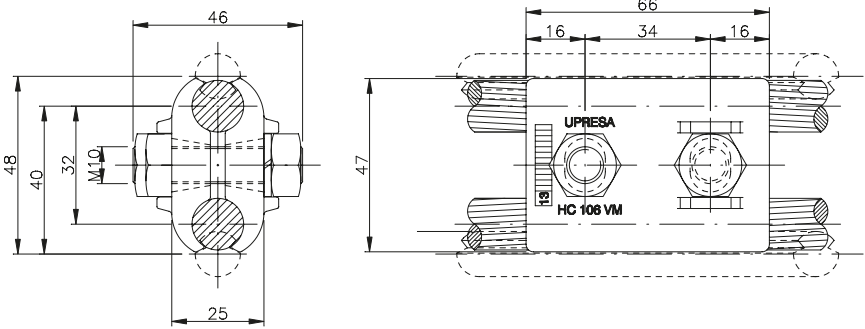
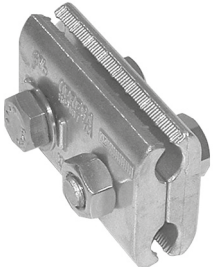

No.	Messenger wire cross section (mm ²)	Feeder cable cross section (mm ²)	Contact wire cross section (mm ²)	Tightening Torque (Nm)	Weight (kg)	References
HC 106 VM	70 - 120	70 - 120	HC 107	20	0,5	

Application pictures:

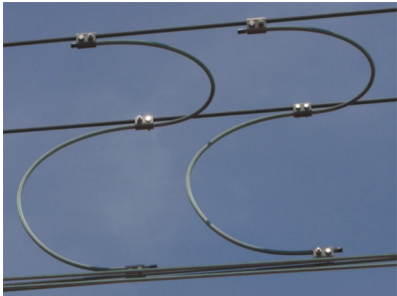

CW and MW connections in Jumper



THORNE & DERRICK INTERNATIONAL

Thorne & Derrick
 +44 (0) 191 490 1547
 www.thorneandderrick.com

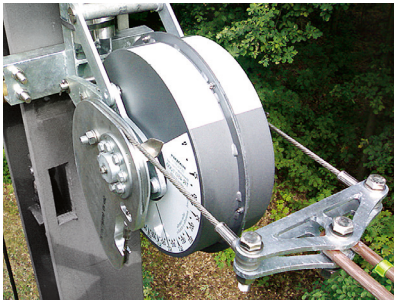

TENSOREX spring charged tensioning system

Modern railways place new demands on tensioning systems: High-speed lines with numerous tunnels require tensioning devices that easily integrate in the tunnel geometry. To an ever increasing extent, urban transport systems are being designed with a focus on aesthetic aspects and require tensioning devices that blend inconspicuously into the overall scheme. TENSOREX, the spring-operated tensioning system offers solutions for both applications.

Further advantages:

- Use of spring tensioning devices for constant tension in contact wires and/or bearer cables
- Suitable for temperature ranges and many span lengths
- Minimum storage and maintenance costs
- Constant tension over entire length of lines
- Highly accurate
- Suitable for all types of catenary poles
- Easy to install - reduced manpower
- Moving parts inaccessible - no protective cage required
- Optional equipment: Telemonitoring system on request

TENSOREX C+

TENSOREX C+ is a patented, automatic tensioning system that uses the force of a coil spring to constantly tension the railway catenary and/or bearer cable. It therefore effectively compensates the expansion caused by fluctuating daytime and nighttime temperatures as well as the change in the seasons while keeping the tension at a constant level.

The TENSOREX C+ features a particularly compact design, making it virtually inconspicuous from an urban planning point of view.

Other versions are available on request.

The components required for mounting on catenary posts can be supplied on request.

No.	Description	PADS No.	Regulating length (mm)	Tensile force (kN)
000700889102	Tensorex TRC+ 375/1150	091/029011	375	11.3
000700890102	Tensorex TRC+ 375/835	091/029012	375	8.195
000700891102	Tensorex TRC+ 375/1985	091/029013	375	19.495
000700680102	Tensorex TRC+ 375/1125	091/029014	375	11
000700490102	Tensorex TRC+ 375/2250	091/029015	375	22
000700892102	Tensorex TRC+ 375/1425	091/029016	375	14
000700893102	Tensorex TRC+ 375/1225	091/029017	375	12
000700894102	Tensorex TRC+ 375/875	091/029018	375	8.56
000700895102	Tensorex TRC+ 375/1215	091/029019	375	11.9
000700896102	Tensorex TRC+ 375/2085	091/029020	375	20.46
000700881102	Tensorex TRC+ 375/1150	091/029021	1000	11.3
000700885102	Tensorex TRC+ 1000/835	091/029022	1000	8.195
000700878102	Tensorex TRC+ 1000/1985	091/029023	1000	19.495
000700886102	Tensorex TRC+ 1000/1125	091/029024	1000	11
000700879102	Tensorex TRC+ 1000/2250	091/029025	1000	22
000700882102	Tensorex TRC+ 1000/1425	091/029026	1000	14
000700883102	Tensorex TRC+ 1000/1225	091/029027	1000	12
000700887102	Tensorex TRC+ 1000/875	091/029028	1000	8.56
000700884102	Tensorex TRC+ 1000/1215	091/029029	1000	11.9
000700880102	Tensorex TRC+ 1000/2085	091/029030	1000	20.46
0007006871.104	Tensorex TRC+ 1000/1680	091/070132	1000	16
000700897104	Tensorex TRC+ 1000/1320	091/070133	1000	13
0007006731.104	Tensorex TRC+ 750/1680	091/070157	750	16
0007010441.104	Tensorex TRC+ 450/1680	091/070158	450	16
000700687104	Tensorex TRC+ 1000/1680	091/070159	1000	16
000700672104	Tensorex TRC+ 750/1320	091/070186	750	13
000700671104	Tensorex TRC+ 450/1320	091/070187	450	13
000700673104	Tensorex TRC+ 750/1680	091/070188	750	16
000701044104	Tensorex TRC+ 450/1680	091/070189	450	16



SICON Power Feed Range

SICON "Power Feed Range" completely eliminates the need for compression tooling which results in:



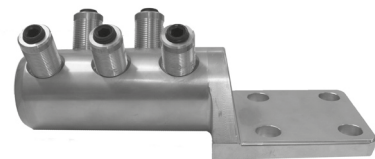
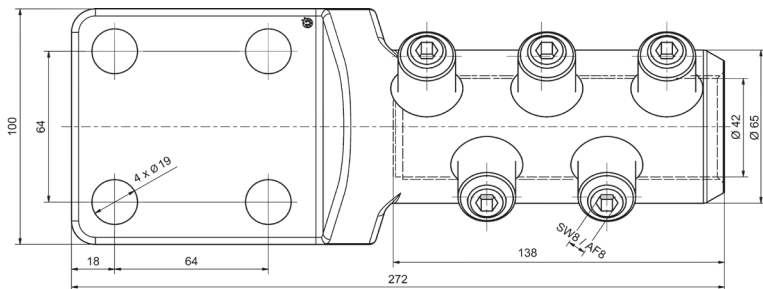

- Less weight for the engineers to transport down the track
- Improved trackside productivity
- Consistent level of installation regardless of the experience of the operator due to the use of stepless shearbolt technology
- No more concerns about tooling calibration
- Can be used with copper and aluminium conductors therefore no need for bi-metallic connectors
- Can be used for multiple conductor sizes

Transformer Connector



No. Width across PADS No. flats

332 594 003	8	054/212152
-------------	---	------------



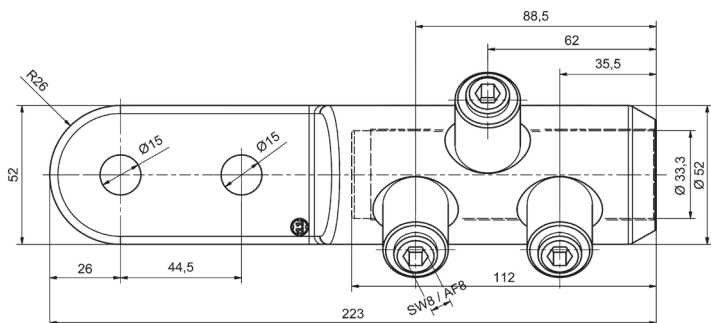

No.	Al  (mm ²)	Al  (mm ²)	Cu  (mm ²)	Cu  (mm ²)
332 594 003	800 - 1000	800 - 1000	800 - 1000	800 - 1000

Rectifier Connector



No. Width across PADS No. flats

332 612 016	8	054/212157
332 612 017	8	054/212158

No.	Al  (mm ²)	Al  (mm ²)	Cu  (mm ²)	Cu  (mm ²)
332 612 016	300 - 630	300 - 630	300 - 630	300 - 630
332 612 017	300 - 630	300 - 630	300 - 630	300 - 630



THORNE & DERRICK INTERNATIONAL

Thorne & Derrick
+44 (0) 191 490 1547
www.thorneandderrick.com

Busbar Connector

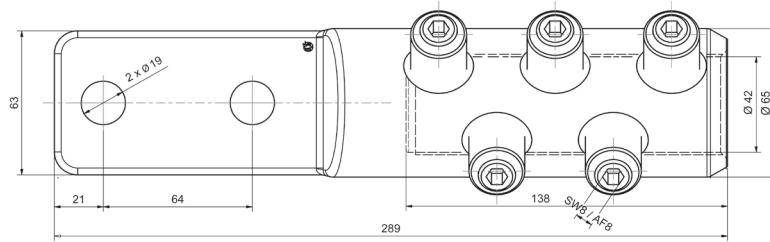

No.	Width across flats	PADS No.
332 594 004	8	054/212154

No.	Al (mm ²)	Al (mm ²)	Cu (mm ²)	Cu (mm ²)
332 594 004	800 - 1000	800 - 1000	800 - 1000	800 - 1000

Hook Switch Connector

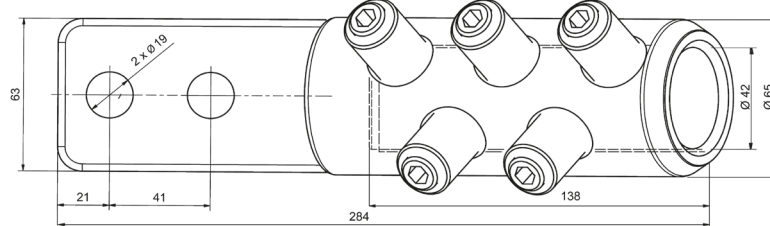

No.	Palm angle	Width across flats	PADS No.
332 594 005	30°	8	054/212159

No.	Al (mm ²)	Al (mm ²)	Cu (mm ²)	Cu (mm ²)
332 594 005	800 - 1000	800 - 1000	800 - 1000	800 - 1000



Conductor Rail Connector

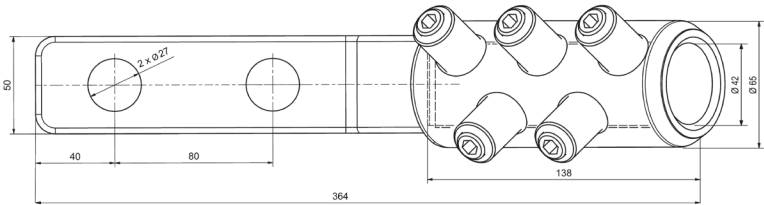

No.	Palm angle	Width across flats	PADS No.
332 594 006	35°	8	054/212160

No.	Al (mm ²)	Al (mm ²)	Cu (mm ²)	Cu (mm ²)
332 594 006	800 - 1000	800 - 1000	800 - 1000	800 - 1000

Through Splice

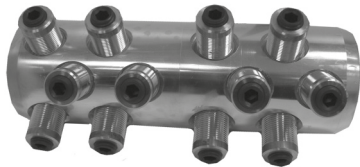
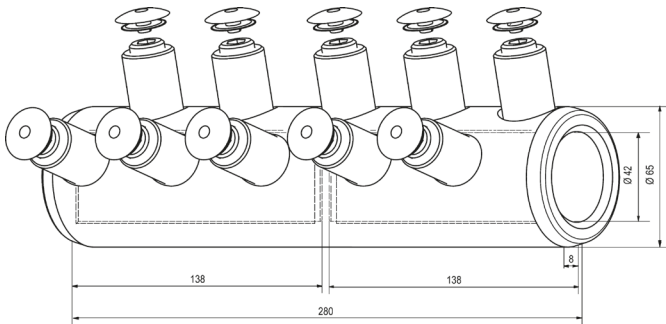

No.	Width across flats	PADS No.
332 645 010	8	054/212169

No.	Al (mm ²)	Al (mm ²)	Cu (mm ²)	Cu (mm ²)
332 645 010	800 - 1000	800 - 1000	800 - 1000	800 - 1000

Cable and Track Connections



THORNE & DERRICK INTERNATIONAL

Thorne & Derrick
+44 (0) 191 490 1547
www.thorneandderrick.com



SICON bolted cable lug

The special design of SICON bolts means that there are no fixed predetermined break points in the thread. Instead the bolt always breaks reliably at the surface of the clamp body.

- Nothing protrudes from the clamp body
- Full use of the thread load rating for any conductor cross section
- No special tools needed
- Smooth breakage of the shear bolt simplifies tightening

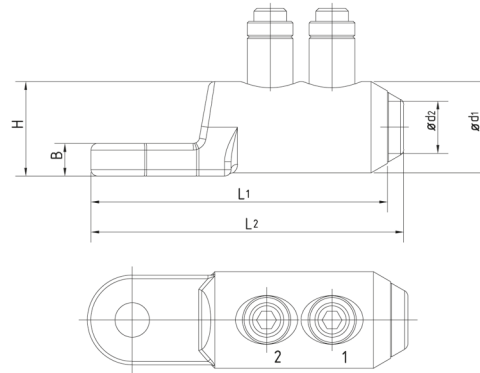

No.	Mounting hole Ø (mm)	Number of screws	Width across flats	Diameter d1 Ø (mm)	Diameter d2 Ø (mm)	Dimension L1 (mm)	Dimension L2 (mm)	Packing unit	PADS No.
332 604 010	13	1	SW 5	24	13	70	75	12	054/212161
332 599 010	13	2	SW 5	28	16.3	91	96	12	054/039337
332 595 010	13	2	SW 6	33	20	115	117	12	054/039338
332 595 011	16.5	2	SW 6	33	20	115	117	12	054/212162
332 595 013	17.2	2	AF 6	33	20	115	117	12	054/212150
332 605 010	13	2	SW 8	38	24	120	123	12	054/212163
332 605 011	16.5	2	SW 8	38	24	120	123	12	054/212164
332 606 010	16.5	3	SW 8	52	33.3	180	184	6	054/212151

No.	Al (mm ²)	Al (mm ²)	Al (mm ²)	Al (mm ²)	Al (mm ²)	Cu (mm ²)	Cu (mm ²)	Cu (mm ²)	Cu (mm ²)
332 604 010	10 - 95	10 - 95	10 - 95	50 - 95	35 - 70	10 - 95	10 - 95	10 - 95	35 - 70
332 599 010	25 - 150	25 - 150	25 - 150	35 - 120	35 - 120	25 - 150	25 - 150	25 - 150	35 - 120
332 595 010	50 - 240	50 - 185	50 - 240	50 - 185	50 - 150	50 - 240	50 - 185	50 - 240	50 - 150
332 595 011	50 - 240	50 - 185	50 - 240	50 - 185	50 - 150	50 - 240	50 - 185	50 - 240	50 - 150
332 595 013	50 - 240	50 - 185	50 - 240	50 - 185	50 - 150	50 - 240	50 - 185	50 - 240	50 - 150
332 605 010	95 - 400	95 - 300	95 - 300	95 - 240	95 - 240	95 - 400	95 - 300	95 - 300	95 - 240
332 605 011	95 - 400	95 - 300	95 - 300	95 - 240	95 - 240	95 - 400	95 - 300	95 - 300	95 - 240
332 606 010	300 - 800	300 - 630	300 - 630	-	300 - 400	300 - 800	300 - 630	300 - 630	300 - 400



**THORNE &
DERRICK
INTERNATIONAL**

Thorne & Derrick
+44 (0) 191 490 1547
www.thorneandderrick.com

SICON connector with blind hole

The special design of SICON bolts means that there are no fixed predetermined break points in the thread. Instead the bolt always breaks reliably at the surface of the clamp body.

- Nothing protrudes from the clamp body
- Full use of the thread load rating for any conductor cross section
- No special tools needed
- Smooth breakage of the shear bolt simplifies tightening

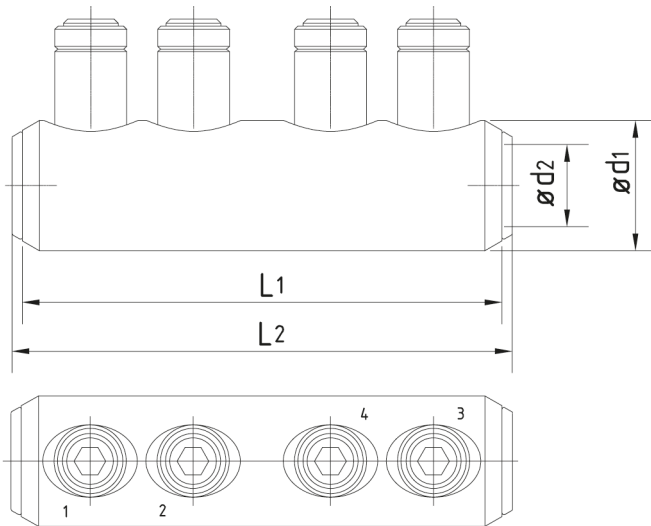

No.	Number of screws	Width across flats	Diameter d1	Diameter d2	Dimension L1	Dimension L2	Packing unit	PADS No.
			Ø (mm)	Ø (mm)	(mm)	(mm)		
332 601 010	2	SW 5	24	13	65	75	12	054/212155
332 593 010	4	SW 5	28	16.3	102	112	12	054/010281
332 592 010	4	SW 6	33	20	126	130	12	054/010282
332 602 010	4	SW 8	38	24	140	146	12	054/212156
332 603 010	6	SW 8	52	33.3	230	238	6	054/212168

No.	Al	Al	Al	Al	Al	Cu	Cu	Cu	Cu
	⊙ (mm ²)	⊙ (mm ²)	⊙ (mm ²)	⊙ (mm ²)	⊙ (mm ²)	⊙ (mm ²)	⊙ (mm ²)	⊙ (mm ²)	⊙ (mm ²)
332 601 010	10 - 95	10 - 95	10 - 95	50 - 95	35 - 70	10 - 95	10 - 95	10 - 95	35 - 70
332 593 010	25 - 150	25 - 150	25 - 150	35 - 120	35 - 120	25 - 150	25 - 150	25 - 150	35 - 120
332 592 010	50 - 240	50 - 185	50 - 240	50 - 185	50 - 150	50 - 240	50 - 185	50 - 240	50 - 150
332 602 010	95 - 400	95 - 300	95 - 300	95 - 240	95 - 240	95 - 400	95 - 300	95 - 300	95 - 240
332 603 010	300 - 800	300 - 630	300 - 630	-	300 - 400	300 - 800	300 - 630	300 - 630	300 - 400





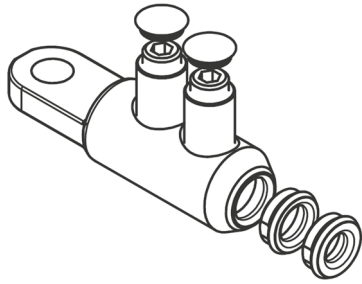

THORNE & DERRICK INTERNATIONAL

Thorne & Derrick
 +44 (0) 191 490 1547
 www.thorneandderrick.com



Lug Connector with Centralised Palm



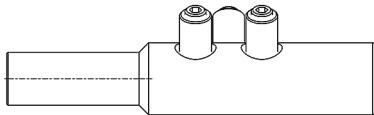

No.	Mounting hole	Number of screws	Width across flats	Diameter D1	Diameter D2	PADS No.
	Ø (mm)			Ø d1 (mm)	Ø d2 (mm)	
332 901 010	17.5	2	-	28	16.3	054/212165
332 900 010	17.5	2	-	28	24	054/212166
332 910 010	17.5	3	AF 8	52	33.3	054/212167

No.	Al	Al	Cu	Cu
	 (mm ²)	 (mm ²)	 (mm ²)	 (mm ²)
332 901 010	25 - 150	25 - 150	25 - 150	25 - 150
332 900 010	95 - 300	95 - 300	95 - 300	95 - 300
332 910 010	300 - 630	300 - 630	300 - 630	300 - 630



Lug Connector Transformer

No.	Number of screws	Diameter D1	Diameter D2	Length	PADS No.
		Ø d1 (mm)	Ø d2 (mm)	(mm)	
332 612 012	3	54	30	278	054/212153

No.	Al	Al	Cu	Cu
	 (mm ²)	 (mm ²)	 (mm ²)	 (mm ²)
332 612 012	300 - 630	300 - 630	300 - 630	300 - 630



RSC-T, new insulation piercing tap-off connector for earth connection cables on railway systems

On railway systems all trackside equipment that has the potential to become live has to be earthed. For this purpose, the earth connection cable must connect properly the ground potential. With RSC-T this is possible without stripping the cable insulation.

Advantages

- easy assembly without stripping the cable insulation
- reduced installation time
- no special tool required
- no cutting of main conductor necessary
- tested according IEC 61284:1997-09 (Class B)
- cover protects against accidental contact, dust and moisture
- consistent and reliable connection due to shear bolt technology
- PADS approval PA05/06096
- PFISTERER part code 331 846 001
- 4 pieces per box
- PADS Number 0091/070198



Product description	External diameter of the conductor (mm)	External diameter of the cable (mm)	Cross section (mm ²)
Main conductor 19/4.22	21.1	25	265.8
Branch conductor 19/3.25	16.25	20	157.5





MV-CONNEX Separable Connectors, Size 3, $U_m = 42 \text{ kV}$, $I_N = 1250 \text{ A}$

Standard article no.

- for DIN VDE cables
- for RM-conductor (stranded circular) of aluminium or copper
- for single core cable with copper wire shield without armouring
- with sealing system (bell flange seal and shrink tubing)
- for indoor and outdoor applications
- not soil-resistant and not offshore-proof
- Packaging unit: set with three cable connectors
- rotatable flange
- offshore version on request
- 3-core version on request

The picture shows an MV-CONNEX cable connector without voltage tap

No.	No.	Max. operating voltage	for cable cross section	for diameter over conductor	Insulation thickness	for diameter over PE/VPE insulation
		U_m (kV)	(mm ²)	(mm)	(mm)	Ø (mm)
850 310 120	870 310 120	12	120	12.5 - 14.7	3.4	19.0 - 23.0
850 310 150	870 310 150	12	150	13.5 - 15.7	3.4	19.0 - 23.0
850 310 185	870 310 185	12	185	15.0 - 17.2	3.4	22.5 - 26.5
850 310 240	870 310 240	12	240	17.5 - 19.7	3.4	24.5 - 28.5
850 310 300	870 310 300	12	300	19.5 - 21.7	3.4	26.0 - 30.0
850 310 400	870 310 400	12	400	22.6 - 24.8	3.4	30.0 - 34.0
850 310 500	870 310 500	12	500	25.4 - 27.6	3.4	32.0 - 36.0
850 310 630	870 310 630	12	630	28.9 - 31.1	3.4	36.0 - 39.5
850 320 050	870 320 050	24	50	7.2 - 9.4	5.5	19.0 - 23.0
850 320 070	870 320 070	24	70	9.0 - 11.2	5.5	19.0 - 23.0
850 320 095	870 320 095	24	95	10.5 - 12.7	5.5	22.5 - 26.5
850 320 120	870 320 120	24	120	12.5 - 14.7	5.5	22.5 - 26.5
850 320 150	870 320 150	24	150	13.5 - 15.7	5.5	24.5 - 28.5
850 320 185	870 320 185	24	185	15.0 - 17.2	5.5	26.0 - 30.0
850 320 240	870 320 240	24	240	17.5 - 19.7	5.5	28.0 - 32.0
850 320 300	870 320 300	24	300	19.5 - 21.7	5.5	30.0 - 34.0
850 320 400	870 320 400	24	400	22.6 - 24.8	5.5	34.0 - 38.0
850 320 500	870 320 500	24	500	25.4 - 27.6	5.5	36.0 - 39.5
850 320 630	870 320 630	24	630	28.9 - 31.1	5.5	40.0 - 43.0
850 330 050	870 330 050	36	50	7.2 - 9.4	8.0	22.5 - 26.5
850 330 070	870 330 070	36	70	9.0 - 11.2	8.0	24.5 - 28.5
850 330 095	870 330 095	36	95	10.5 - 12.7	8.0	26.0 - 30.0
850 330 120	870 330 120	36	120	11.5 - 13.7	8.0	28.0 - 32.0
850 330 150	870 330 150	36	150	13.5 - 15.7	8.0	30.0 - 34.0
850 330 185	870 330 185	36	185	15.0 - 17.2	8.0	32.0 - 36.0
850 330 240	870 330 240	36	240	17.5 - 19.7	8.0	34.0 - 38.0
850 330 300	870 330 300	36	300	19.5 - 21.7	8.0	36.0 - 39.5
850 330 400	870 330 400	36	400	22.6 - 24.8	8.0	38.0 - 41.0
850 330 500	870 330 500	36	500	25.4 - 27.6	8.0	42.0 - 44.5
-	870 330 630	36	630	28.9 - 31.1	8.0	45.5 - 48.0
-	870 335 630	52	800	28.9 - 31.1	8.0	45.0 - 55.0



MV-CONNEX Separable Connectors, Size 3-S,
 $U_m = 52 \text{ kV}, I_N = 1250 \text{ A}$

Standard article no.

- for RM-conductor (stranded circular) of aluminium or copper
- for single core cable with copper wire shield without armouring
- with sealing system (bell flange seal and shrink tubing)
- for indoor and outdoor applications
- not soil-resistant and not offshore-proof
- Packaging unit: set with three separable connectors
- Voltage taps that are not connected to a voltage display system, must be earthed for size 3-S
- rotatable flange
- offshore version on request
- 3-core version on request



No.	No.	Max. operating	for cable	for diameter	for diameter
		voltage	cross section	over conductor	over PE/VPE insulation
		U_m (kV)	(mm ²)	(mm)	Ø (mm)
850 350 120	-	52	120	11.5 - 13.7	32.0 - 36.0
850 350 150	-	52	150	13.5 - 15.7	36.0 - 39.5
850 350 185	-	52	185	15.0 - 17.2	36.0 - 39.5
850 350 240	-	52	240	17.5 - 19.7	38.0 - 41.0
850 350 300	-	52	300	19.5 - 21.7	38.0 - 41.0
850 350 400	-	52	400	22.6 - 24.8	40.0 - 43.0
850 350 500	-	52	500	25.4 - 27.6	43.5 - 46.0
-	870 350 630	52	630	28.9 - 31.1	47.5 - 50.0

Cable and Track Connections



**THORNE &
 DERRICK
 INTERNATIONAL**

Thorne & Derrick
 +44 (0) 191 490 1547
 www.thorneandderrick.com



Voltage Detectors KP-Test 5H

The **KP-Test 5H** capacitive voltage detector has universal high voltage application for nominal voltages from 30 to 420 kV. It indicates the presence of operating voltage when brought into contact with the conductor. The **KP-Test 5H** voltage detector is distinguished by its high level of user-friendliness and user safety.

Technical description:

- Available for different ranges of nominal voltages from 30 to 420 kV
- Can be used in rain and snow
- Particularly loud, integrated audible signal for reliable voltage tests even in a noisy environment
- Extremely bright LEDs in clear layout to prevent confusion
- Maximum resistance to interference fields through the use of a high-quality contact electrode extension
- Extensive self-test functions at switch-on
- Available separately for use with existing insulating poles
- Available complete with suitable insulating poles in any overall length or carrying length
- Insertion depth $A_i = 898$ mm
- Nominal frequency 50 Hz, optional 60 Hz

The **KP-Test 5H** is constructed and type-tested to Standard IEC 61243-1.

The **KP-Test 5H** Series voltage detector is also available with a carrying case on request. Other versions with deviating nominal voltages, ranges of nominal voltage, frequencies and languages are available on request.

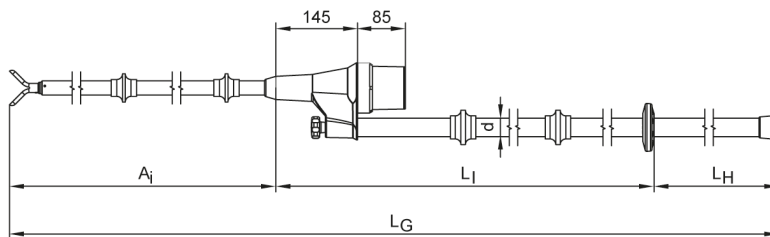

No.	Version	Nominal voltage	Insulating length	Total length	Transporting length	Number of insulating poles	Suitable bag
		U_n (kV)	L_i (mm)	L_G (mm)	L_T (mm)		
930 250 001	0136	33 - 66 kV / 50 Hz	975	2478	1485	1	B5
930 250 001	0167	66 - 132 kV / 50 Hz	1802	3700	1855	2	B2
930 250 001	0048	110 kV / 50 Hz	1802	3700	1855	2	B2
930 250 001	0008	110 - 220 kV / 50 Hz	3220	5118	2050	3	B2
930 250 001	0078	220 - 420 kV / 50 Hz	3850	5748	2050	3	B2
930 250 001	0038	400 kV / 50 Hz	3850	5748	2050	3	B2

Voltage Detectors for Railway Systems

Electric railway systems around the world are operated with different voltage systems. PFISTERER can supply voltage detectors for all common voltage systems.

- 15 kV at 16.7 Hz
- 25 kV at 50 Hz
- 1500 V DC
- 3000 V DC
- Voltage supply for trolley lines
- Voltage supply for urban rail systems with third rail

Depending on type, our voltage detectors are suitable for use on railway catenaries and power lines as well as on switchgear.



Voltage Detectors KP-Test 5R 25 kV for Catenaries

The **KP-Test 5R 25 kV 50 Hz** capacitive voltage detector designed for use on railway catenaries. It indicates the presence of operating voltage when brought into contact with the conductor.

Technical Description:

- Bright LEDs for clear recognition
- Particularly loud, integrated audible signal
- Extensive self-test functions at switch-on
- Contact electrode in hook form with contact pin for optimum contact with the catenary
- For single-phase networks

Versions in other languages or with other signal mode are available on request.

No.	Version	Total length	Transporting length	Suitable bag	Carrying bag included
		L _G (mm)	L _T (mm)		
930 300 001	0007	4795	2460	B3	-



III
Safety Equipment



**THORNE &
DERRICK
INTERNATIONAL**

Thorne & Derrick
+44 (0) 191 490 1547
www.thorneandderrick.com



Voltage Detectors KP-Test 5R 25 kV for Catenaries, Separable

The **KP-Test 5R 25 kV 50 Hz** capacitive voltage detector designed for use on railway catenaries. It indicates the presence of operating voltage when brought into contact with the conductor.

For transport in service vehicles the voltage detector can be dismantled into five separate components.

Technical Description:

- Bright LEDs for clear recognition
- Particularly loud, integrated audible signal
- Extensive self-test functions at switch-on
- Separable contact electrode in hook form with point-contact for optimum contact with the catenary
- For single-phase networks

Versions in other languages or with other signal mode are available on request.

No.	Version	Total length	Transporting length	Suitable bag	Carrying bag included
		L _G (mm)	L _T (mm)		
930 300 601	0009	4785	1100	B1	-



Voltage Detectors KP-Test 5R DC

The **KP-Test 5R DC** double-pole voltage detector is designed for use on the catenary systems of DC voltage railways. It indicates the presence of operating voltage when brought into contact with the conductor. With its extensive, integrated self-tests, the **KP-Test 5R DC** voltage detector ensures maximum user safety.

Technical description:

- Double-pole type for the catenary systems of DC voltage railways with nominal voltages between 500 and 4,000 V DC
- Second pole designed with practical magnetic connection to rail
- Hook-type contact electrode with high-quality contact pin for optimum contact
- Self-test at switch-on also checks the connecting cable
- Can be used in rain and snow
- Integrated audible signal for reliable voltage tests even in a noisy environment
- Extremely bright LEDs in clear layout to prevent confusion
- Induced AC voltage signal detection
- Voltage testing possible even with a high proportion of leakage current on disconnected contact wires
- Available separately without insulating pole
- Available separately without insulating pole, but with additional adapters
- Available complete with three-piece insulating pole (poles **RP1** and **UP**; total length about 5,000 mm), or five-piece insulating pole (poles **RP2**, **RP3**, **RP4** and **UP**; total length about 4,880 mm)
- Available with convenient carrying case

Other versions with deviating nominal voltages, ranges of nominal voltage and languages are available on request.

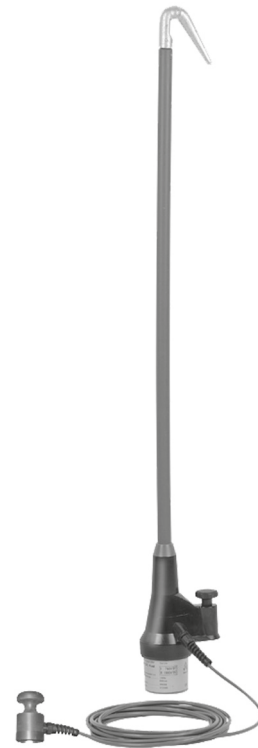

Safety Equipment

No.	Version	Nominal Voltage DC	Transporting length	Number of insulating poles	Suitable bag
		U_n (V)	L_T (mm)		
930 350 001	0097	650 - 750	2450	2	B3
930 350 001	0085	1500	2450	2	B3
930 350 001	0077	3000	2450	2	B3 (incl.)



**THORNE &
DERRICK
INTERNATIONAL**

Thorne & Derrick
+44 (0) 191 490 1547
www.thorneandderrick.com

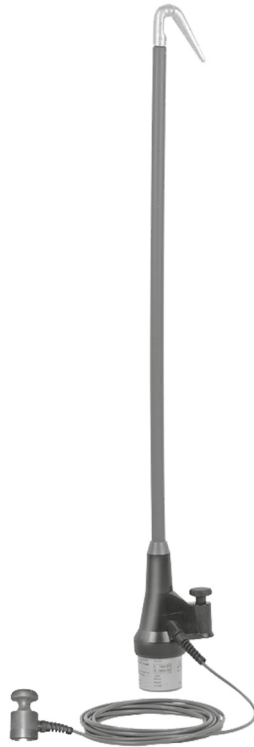

Voltage Detectors KP-Test 5R DC dual

The **KP-Test 5R DC dual** double-pole voltage detector is similar in design to the **KP-Test 5R DC**. In addition, this voltage detector can be switched between two nominal voltage ranges in two steps. This allows a larger system range to be covered even when there is a high proportion of leakage current.

The KP-Test 5R DC dual has two selectable voltage steps.

Step 1:

- Selected by briefly pressing the On button
- LED indicator: 1 x green

Step 2:

- Selected by pressing and holding the On button
- LED indicator: 2 x green

Deliberate voltage level selection at switch-on and the related self-test ensure that the **KP-Test 5R DC dual** displays safe, clear indications.

Technical description:

- Double-pole type for the catenary systems of DC voltage railways with nominal voltages between 500 and 4,000 V DC
- Second pole designed for practical magnetic connection to rail
- Voltage range selectable
- Hook-type contact electrode with high-quality contact pin for optimum contact
- Self-test at switch-on also checks the connecting cable
- Can be used in rain and snow
- Integrated audible signal for reliable voltage tests even in a noisy environment
- Extremely bright LEDs in clear layout to prevent confusion
- Induced AC voltage signal detection
- Voltage testing possible even with a high proportion of leakage current on disconnected contact wires
- Available separately without insulating pole
- Available separately without insulating pole, but with additional adapter
- Available complete with three-piece insulating pole (poles **RP1** and **UP**; total length about 5,000 mm), or five-piece insulating pole (poles **RP2**, **RP3**, **RP4** and **UP**; total length about 4,880 mm)
- Available with convenient carrying case

Other versions with deviating nominal voltages, ranges of nominal voltage and languages are available on request.

No.	Version	Nominal voltage DC Level I	Nominal voltage DC Level II	Transporting length	Number of insulating poles	Suitable bag
		U_n (V)	U_n (V)	L_T (mm)		
930 350 501	0007	600	1200	1111	-	B1
930 350 501	0008	600	1200	2450	2	B3
930 350 501	0009	600	1200	1111	4	B1
930 350 501	0010	750	1,500	1111	-	B1
930 350 501	0011	750	1,500	2450	2	B3
930 350 501	0012	750	1,500	1111	4	B1



**THORNE &
DERRICK
INTERNATIONAL**

Thorne & Derrick
+44 (0) 191 490 1547
www.thorneandderrick.com

Voltage Detectors KP-Test 5 DC

The **KP-Test 5 DC** Double-pole voltage detector is suitable for use on the switchgear of DC voltage railways as well as railway systems with a third rail. It indicates the presence of operating voltage when brought into contact with the conductor. With its extensive, integrated self-tests, the **KP-Test 5 DC** voltage detector ensures maximum user safety. It also provides maximum ease of operation.

Technical description:

- Double-pole type for use on the switchgear of DC railways as well as on railways with a third rail and nominal voltages between 500 and 4,000 V DC
- Self-test at switch-on also checks the connecting cable
- Can be used in rain and snow
- Integrated audible signal for reliable voltage tests even in a noisy environment
- Extremely bright LEDs in clear layout to prevent confusion
- Induced AC voltage signals detected

Other versions with deviating nominal voltages, ranges of nominal voltage and languages are available on request.



No.	Version	Nominal voltage	Total length	Transporting length	Cable length	Suitable bag
		U_N	L_G (mm)	L_T (mm)	(mm)	
930 370 001	0020	750 V DC	815	572	1000	A1

III
Safety Equipment



**THORNE &
DERRICK
INTERNATIONAL**

Thorne & Derrick
+44 (0) 191 490 1547
www.thorneandderrick.com



Rail earthing clamps

PFISTERER offers a range of rail earthing clamps for railway lines.



Rail earthing clamps R50

This rail earthing clamp is suitable for all rail base gauges. The small overall height of 35 mm below the rail base makes removal of gravel unnecessary. A separate handle allows easy placing of the clamp and protects the earth wire connection. When tightening the clamp, the annular cutting edge cuts through layers of dirt and oxide, thus ensuring reliable contact. The counter-surface, a hardened metal tip, is spring-mounted and insulated. The clamp is therefore flame-resistant in the event of a short circuit.

No.	Max. cross section of connected cable (mm ²)	Max. short-circuit current I _k 0,12 s (A)	With ratchet mit Ratsche	Weight (g)	DB drawing-no.
363 322 005	50	40000	■	2128	3 Ebgw 01.13
363 322 006	50	40000	-	1706	-

Rail earthing clamps R51

This rail earthing clamp is designed as an earthing magnet for use on trolley lines.



No.	Max. cross section of connected cable (mm ²)	Max. short-circuit current I _k 1 s (A)	Weight (g)
364 901 001	70	13800	5000

Rail earthing clamps R52

These rail earthing clamps are suitable for use on grooved rails.



No.	Max. cross section of connected cable (mm ²)	Max. short-circuit current I _k 0,12 s (A)	Weight (g)
364 868 001	50	40000	858



Contact Wire Laser Measuring Device

This unit is used to measure the height and stagger of the contact wire using laser measuring technology.

Application:

- Height, stagger and cant measuring

Technical description:

- Laser measures
- No need touching wires
- Used in any weather conditions
- Bluetooth Smart 4.0
- Cant gauge
- Easy transportation



No.	ID-Code	Track width (mm)	Measuring range, on the stagger (MR) (mm)	Data information
304 132 001	GLI-7LI.60	1435	+/- 600	Weight: 9 kg



**THORNE &
DERRICK
INTERNATIONAL**

Thorne & Derrick
+44 (0) 191 490 1547
www.thorneandderrick.com



THORNE &
DERRICK
INTERNATIONAL

Thorne & Derrick
+44 (0) 191 490 1547
www.thorneandderrick.com



THORNE &
DERRICK
INTERNATIONAL

Thorne & Derrick
+44 (0) 191 490 1547
www.thorneandderrick.com